

Synthesis of Blue Pigment from Kaolin

Amin Ur Rahman*, Faridullah Khan, Muhammad Riaz and Atif Latif

Materials Science Center, PCSIR Laboratories Complex, Peshawar-25120, Pakistan

(received December 18, 2007; revised January 14, 2009; accepted January 19, 2009)

Abstract: Kaolin of Swat NWFP, Pakistan was analyzed and its suitability was tested for utilizing the raw material for the synthesis of blue pigment. It was successfully utilized for the preparation of ultramarine blue pigment by subsequent reductive and oxidative heating with other ingredients. The pigment was characterized by UV-Vis, IR spectrophotometry and XRD.

Keywords: kaolin, ultramarine blue, pigment, Swat, Pakistan

Introduction

Ultramarines family of pigments are derived from sodalite ($6\text{NaAlSi}_3\text{O}_8 \cdot 2\text{NaCl}$) doped with sulphur and are used in the manufacture of textiles, synthetic fibers, detergents, soaps, plastics, toys, ropes and mats, cosmetics etc. The catalytic activity of ultramarine is also reported and is thus used for dehydrogenation, dehydro-sulphurization, cracking and isomerization purposes (Kowalak *et al.*, 2004).

Natural ultramarines i.e., lazurite and lazuli are known. Ultramarine is available in different colours and shades i.e., blue, reddish blue, greenish blue, red, pink and violet. Ultramarine blue consists of aluminosilicate framework, containing sodium cations and poly-sulphide anions (S^{2-} , S^{3-}) (Tarling, *et al.*, 1988) in which the S^{3-} species are dominant over S^{2-} . The S^{3-} is responsible for the intense blue colour of the pigment.

Basic raw material for ultramarine is kaolin (Booth *et al.*, 2003; Cork, 1993). Kaolin is largely used in ceramics and as filler in paper, plastics and rubbers. Synthesis of ultramarine is still based on J. B. Guimet method (Kowalak *et al.*, 2004). The aim of the present research was production of ultramarine blue for industrial use utilizing kaolin ($\text{Al}_2\text{Si}_2\text{O}_5(\text{OH})$) of Swat, NWFP, Pakistan. Kaolin deposits of Swat lie $34^\circ 53' 30'' \text{N}$, $72^\circ 53' 30'' \text{E}$ and are among the oldest known kaolin deposits of Pakistan (Siddiqui *et al.*, 2005). The reported deposits of Swat kaolin are 2.5 million tons (Yotoni *et al.*, 1967).

Materials and Methods

Kaolin sample was collected from Shah Dehri, Swat, NWFP, Pakistan. The sample was analyzed gravimetrically (Furman, 1962) and trace metals were determined using atomic absorption spectrophotometer (Hitachi Z8000, Japan) (Table 1). Moisture content, water-soluble content and pH of the sample were also determined (Table 2).

* Author for correspondence; E-mail: aminpcsir@yahoo.com

Steps of pigment production are given in the flow diagramme (Fig. 1). Kaolin sample was activated/dehydrated at 700°C in a muffle furnace for 2 h and afterwards mixed with sodium carbonate and charcoal in optimized ratio. The mixture was then finely grinded and blended with fine sulphur. All the chemicals were of commercial grade. The blend was packed in ceramic vessel, covered with mud, kept in muffle furnace and heated to 800°C for 5 h. After cooling the reduced greenish product was grinded and heated in open air in a china dish, till the colour changed to blue. The blue pigment was washed with hot water several times and then with 10% sodium hydroxide solution to remove soluble matter i.e., sulphates. The product was then dried in air.

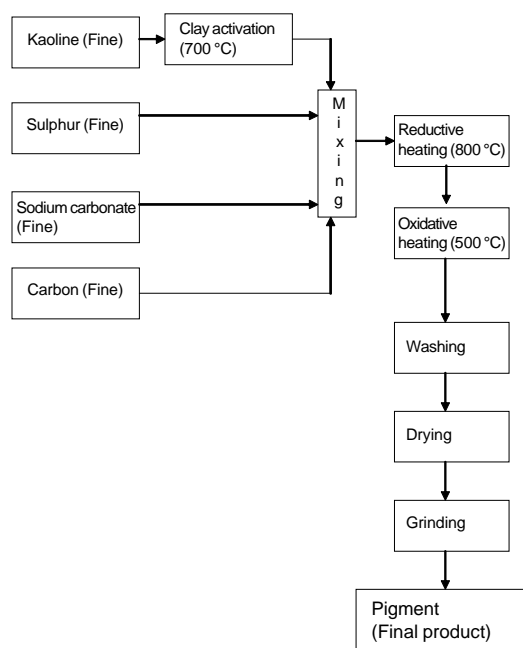

Fig. 1. Flow diagram for the production of blue pigment from kaolin

Density, water-soluble matter and free sulphur of the product were determined (Table 3). The pigment was characterized by double beam UV-visible spectrophotometer (Hitachi, U2000), FTIR (Shimadzu Prestige-21) and XRD (Jeol, JDX3532, Japan).

Results and Discussion

The raw materials used in this synthesis are kaolin, sulphur, coal and Na_2CO_3 . The kaolin composition is given in Table 1. The ratio of Si to Al is 1.88. Si and Al form the main framework and their ratio is very important. Variation in Si:Al ratio affects the shade of the pigment (Klinowski *et al.*, 1987). Kaolin having Si:Al, 1.66 has already been successfully used for ultramarine preparation (Landman and De Waal, 2004). Trace metals are not in appreciable quantity to disturb the synthesis of ultramarine. The amount of Fe_2O_3 is 0.8%. The quantity of iron not only affects the synthesis of the pigment but also its quality. Ultramarines having heavy metals are toxic.

Moisture of kaolin is 4.761% (Table 2) and earlier trials with unactivated samples were not successful. The sample was therefore, activated at 700 °C to remove water and hydroxyl ions and also to weaken the structure of kaolin. The pH of the sample was suitable for the synthesis (Table 2).

Table 1. Chemical constituents of kaolin

Compounds	Composition (%)
SiO_2	48.254
Al_2O_3	37.424
CaO	4.479
MgO	1.365
Fe_2O_3	0.805
PbO	0.003
CoO	0.004
CuO	0.033

Table 2. Physical properties of kaolin

Parameters	Value
pH	5.49
Water soluble matter	3.659%
Moisture	4.761%

Table 3. Properties of the synthesized ultramarine blue

Parameters	Value
Moisture	0.08%
Water soluble matter	2.05%
Free sulphur	0.27%
Density	1.429%

The pigment was prepared in two steps i.e., reductive and oxidative heating. In the first step the ingredients were packed in a vessel and tightly covered and then heated at 800 °C in a furnace for 4 h. The green pigment formed was then oxidized in open air, which changed the colour to blue. Overheating and under heating of the reactants in the crucible lead to heterogeneous product.

The nature of these steps is controversial. Some suggests as follows (Gruen *et al.*, 1971).

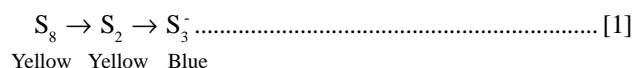

While others propose (Cork, 1993):

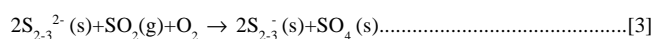
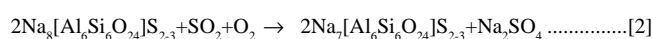

At 800 °C, alumino silicate framework is formed and the encaged polysulphides act as chromophores. Beta cage consisting of SiO_4 and AlO_4 forms aluminosilicate framework. Sodium cations also enter the cage and those outside the frame act as counter ions to balance the charges of polysulphides. These sodium ions are important and affect the shade of pigment. Ultramarines are similar to zeolites and sodium ions could be exchanged to other cations like K, Li, Ca, Mg, Ag, Rb, Cs, Sr, Ba, Tl, and Pt.

There are two forms of polysulphides i.e., S^{2-} and S^{3-} . In the greenish pigment S^{2-} are present. In the oxidative step S^{2-} is oxidized to S^{3-} form. In the blue pigment both S^{2-} and S^{3-} are present but S^{3-} dominates over S^{2-} species. The UV-visible spectrum of the pigment is shown in Fig. 2. A peak at ~600 nm and ~350 nm conforms the presence of S^{3-} (Lindner *et al.*, 1995). The peak at 350 nm is due to sodalite framework. The absorption at 600 nm indicates blue color of the pigment. Infrared spectroscopy is used for the confirmation of the sodalite structure formation. IR spectrum (Fig. 3) of the pigment also shows the presence of thiosulphatate and sulphate. XRD patterns of

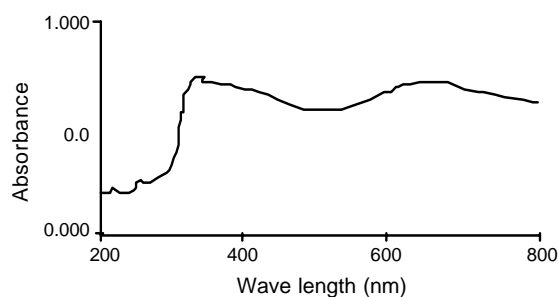

Fig. 2. UV-visible spectrum of blue pigment (suspension in glycerin).

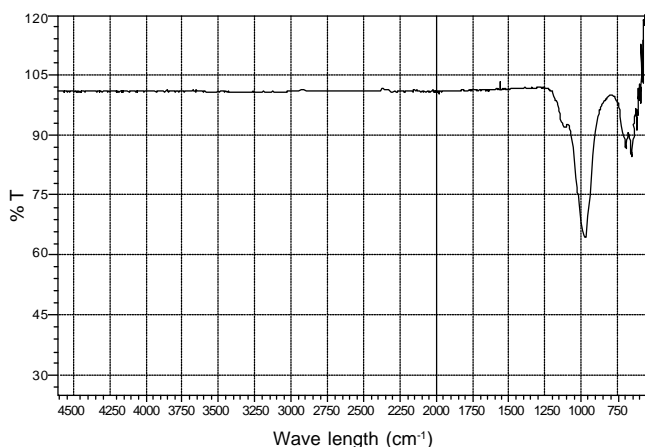

Fig. 3. FTIR spectrum of blue pigment.

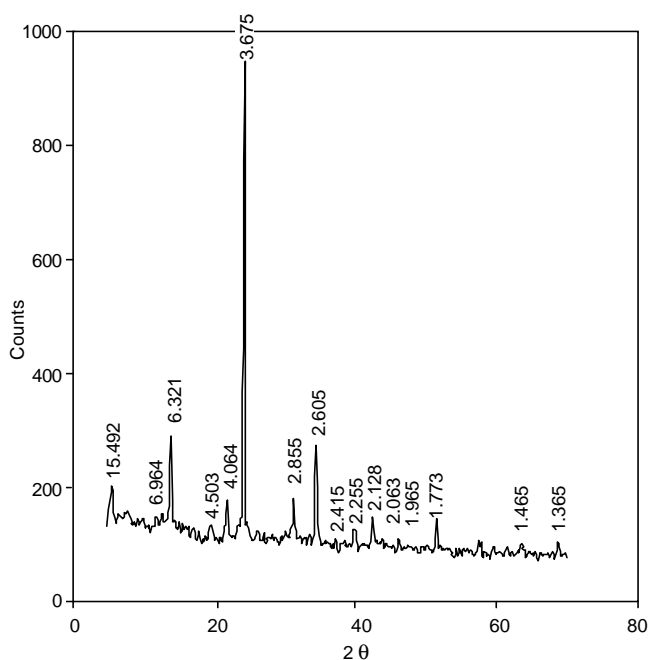

Fig. 4. XRD pattern of blue pigment.

the pigment (Fig. 4) matches well with the XRD pattern of the ultramarine blue (JCPDS-ICCD, 2000). XRD also confirms the presence of sodium sulphate in the pigment.

Conclusion

Composition of Swat kaolin is suitable for the preparation of ultramarine blue. Metals like iron, lead and copper are not in

appreciable quantity to affect the synthesis of the pigment. Activated kaolin could be utilized for the preparation of ultramarine blue.

References

- Booth, D. G., Dann, S. E., Weller, M. T. 2003. The effect of the cation composition on the synthesis and properties of ultramarine blue. *Dyes and Pigments* **58**: 73-82.
- Cork, W. B. 1993. Ultramarine pigments. In: *Industrial Inorganic Pigments*, G. Buxbaum (ed.), pp.124-132, VCH, Weinheim, New York, USA.
- Furman, N. H. 1962. *Standard Methods of Chemical Analysis*, vol. 1, 6th edition. D. Van Nostrand Company Inc., Princeton, New Jersey, USA.
- Gruen, D. M., McBeth, R. L., Zielen, A. J. 1971. Nature of sulfur species in fused salt solution. *Journal of The American Chemical Society* **93**: 6691-6693.
- JCPDS-ICCD 2000 Joint Committee on Powder Diffraction Standards-International Center for Diffraction Data. Entry No. 36-0796, 02-0338 (N), 77-1702 (C).
- Klinowski, J., Carr, S. W., Tarling, S. E., Barnes, P. 1987. Magic-angle-spinning NMR shows the aluminosilicate framework of ultramarine to be disordered. *Nature* **330**: 56-58.
- Kowalak, S., Jankowska, A., Laczkowska, S. 2004. Preparation of various color ultramarine from zeolite A under environment-friendly condition. *Catalysis Today* **90**: 167-172.
- Landman, A. A., De Waal, D. 2004. Fly ash as a potential starting reagent for the synthesis of ultramarine blue. *Materials Research Bulletin* **39**: 655-667.
- Lindner, G. -G., Massa, W., Reinen, D. 1995. Structure and properties of hydrothermally synthesized thiosulfate concretionite. *Journal of Solid State Chemistry* **117**: 386-391.
- Siddiqui, M. A., Ahmed, Z., Saleemi, A. A. 2005. Evaluation of Swat kaolin deposits of Pakistan for industrial uses. *Applied Clay Science* **29**: 55-72.
- Tarling, S. E., Barnes, P., Klinowski, J. 1988. The structure and Si, Al distribution of the ultramarine. *Acta Crystallographica B* **44**: 128-135.
- Yotoni, K., Miyaji, S., Yamado, K., Shigeyuki, Y. 1967. Report on the Feasibility Survey for the Development of Swat China Clay. Japan Consulting Institute. Report for Pakistan Mineral Development Corporation, Islamabad, Pakistan.